





Butler

Navigator

**NAV
26HW**

**NAV
26HW.T**

-  **SMONTAGOMME PER SERVIZIO MOBILE O IN OFFICINA**
-  **TYRE CHANGER FOR ROAD-SIDE AND WORKSHOP SERVICE**
-  **MONTIERGERÄT FÜR DEN MOBILEN ODER STATIONÄREN EINSATZ**
-  **DÉMONTÉ-PNEUS POUR SERVICE MOBILE OU EN ATELIER**
-  **DESMONTADORA PARA SERVICIO MÓVIL O EN EL TALLER**

NAV26HW.T

Smontagomme autocarro retrattile, adatto sia a furgoni chiusi che a furgoni telonati. Ideale per assistenza pneumatici su strada, può operare sia su pneumatici autocarro che agricoli.

Retractable truck tyre changer suitable for closed vans. Ideal for road-side tyre service, it is suitable for both truck and also for agricultural tyres.

Einfahrbares LKW-Montiergerät, geeignet für Lieferwagen und geschlossene Anhänger. Ideal für den Serviceeinsatz auf der Strasse, es kann sowohl LKW- als auch Landwirtschaftsräder montieren.

Démonté-pneus PL rétractile, apte soit aux fourgons fermé qui aux fourgons bâchés. Idéal pour assistance pneus sur rue, il peut opérer soit sur pneumatiques PL que agricoles.

Desmontadora para camiones retráctil, ideal para furgonetas cerradas o furgonetas con toldo carrozadas. Perfecta para asistencia de neumáticos en carretera, puede operar tanto con neumáticos para camiones cuanto con neumáticos agrícolas.

NAV26HW

Smontagomme autocarro per servizio mobile o in officina, adatta a furgoni telonati o piccole officine. Comandi su consolle.

Truck tyre changer for both road-side and workshop service, suitable for closed vans and/or small workshops. Controls on console.

Montiergerät für den mobilen oder stationären Einsatz, geeignet für geschlossene Anhänger oder Kleinwerkstätte. Pultsteuerung.

Démonté-pneus PL pour service mobile ou en atelier. Il adapte aux fourgons bâchés ou pour petits ateliers. Commandes sur console.

Desmontadora para camiones para servicio móvil o para servicio en el taller, ideal para furgonetas con toldo carrozadas o pequeños talleres. Mandos en la consola.



TYRE CHANGER



QUICK Demounting

QUICK Mounting



Easy Setting



Hydraulic Wheel Clamping

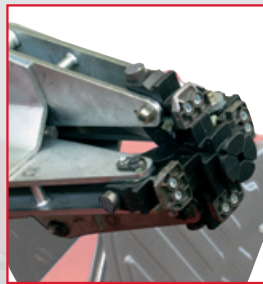

Minimum Clamping
Ø 90 mm (3,5")

VARGNAV26TBT
(→ NAV26HW.T)



Variante per comandi Bluetooth
Version with Bluetooth controls

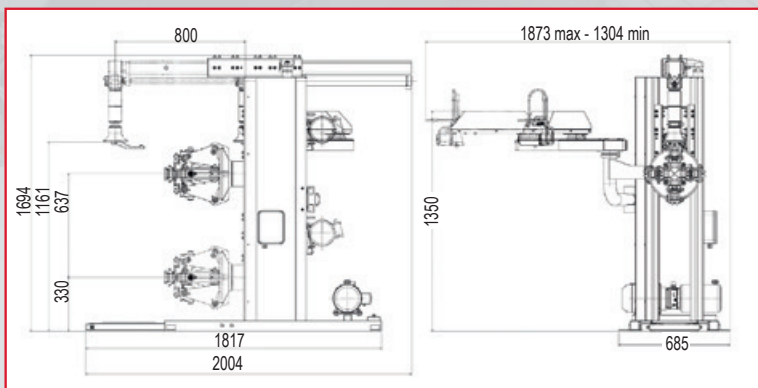

NAV 26HW

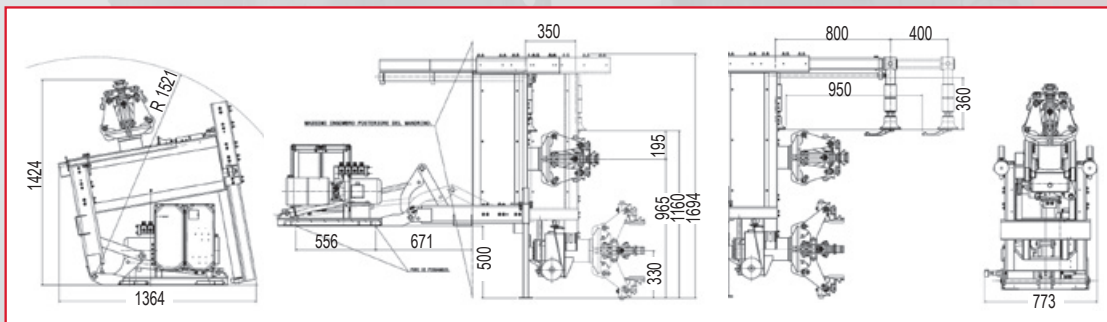

NAV 26HW.T

STANDARD

(→ TUBE TYRES)



OPTIONS



G108A2 (→ NAV26HW)
ALU PROTECTION (4 x kit)



G108A22
Disc for wheels with lock ring



G90A6
Alu rim clamp

DATI TECNICI	TECHNICAL DATA	TECHNISCHE DATEN	DONNEES TECHNIQUES	DATOS TÉCNICOS	NAV26HW	NAV26HW.T
Motore rotazione mandrino	Chucking unit rotation motor	Motor für Umdrehung der Spannvorrichtung	Moteur rotation mandrin	Motor rotación plato	1,1 kW	1,5 kW
Motore centralina	Hydraulic drive unit motor	Hydraulikmotor	Moteur de la pompe	Motor unidad hidráulica	2 kW	2,2 kW
Ø cerchi	Rim Ø	Felgen-Ø	Ø de la jante	Ø de llantas	11" - 27"	
Ø est. ruota ammesso	Max. wheel Ø	Raddurchmesser	Ø de la roue	Ø maximo ext. rueda	1300 mm (51")	
Larghezza max. ruota	Max. allowed wheel width	Max. Radbreite	Largueur maxi de la roue	Ancho max. rueda	950 mm (37.4")	
Peso macchina	Weight	Gewicht	Poids	Peso	378 kg	470 kg
Potenza stallonatore	Bead breaker power	Abdrückerkraft	Force du détalonneur	Force du détalonneur	16000 N	
Peso max ruota	Max wheel weight	Maximales Radgewicht	Poids maxi de la roue	Poids maxi de la roue	1200 kg	
Velocità di rotazione (giri/min)	Chuck rotation speed (rev/min)	Sperrvorrichtungs-Drehgeschwindigkeit (U./min.)	Vitesse de rotation du mandrin (tours/min.)	Velocidad de rotación mandril (rev./min.)	8	
Coppia max rotazione	Max. torque to chuck	Max. Sperrvorrichtungs-Drehmoment	Couple max. au mandrin	Par máx al mandril	1700 Nm (1253 Ft/Lbs)	2200 Nm (1620 Ft/Lbs)

Butler

Engineering and Marketing S.p.A. a.s.u.
Via dell'Ecologia 6 - 42047 Rolo (RE)
Ph. +39-0522-647911 - Fax +39-0522-649760
www.butler.it - info@butler.it

A DOVER COMPANY

Le caratteristiche tecniche e gli allestimenti presentati in questo prospetto possono subire variazioni. Le immagini riprodotte non sono vincolanti.
Technical data and composition presented in this catalogue may vary. Pictures reproduced are only indicative.
Die techn. Daten und die Ausrüstungen, die in diesem Prospekt enthalten sind, können Änderungen erfahren. Deshalb sind die Abbildungen unverbindlich.
Les caractéristiques techniques et les compositions présentées dans ce prospectus peuvent subir des variations. Les images reproduites n'ont qu'une valeur indicative.
Las características técnicas y las composiciones ilustradas en este folleto pueden sufrir variaciones. Las imágenes propuestas son solamente indicativas.